

TERASIC CYCLONE II EP2C35 DAUGHTER BOARD

SCHEMATIC	CONTENT	PAGE
TOP	COVER PAGE , TOP	01 ~ 03
AUDIO	WM8731	04 ~ 04
DISPLAY	LCD , LED , 7SEGMENT	05 ~ 06
EP2C35	EP2C35 BANK1..BANK8 , POWER , CONFIG	07 ~ 11
ETHERNET	DM9000A	12 ~ 12
INPUT	CLOCK , PS2 , RS232 , KEY , SWITCH , CONNECT	13 ~ 17
MEMORY	SRAM , DRAM , FLASH , SD CARD	18 ~ 19
POWER	POWER	20 ~ 20
USB BLASTER	USB BLASTER	21 ~ 21
USB DEVICE	USB DEVICE	22 ~ 22
VIDEO	ADV7181 , ADV7123	23 ~ 24

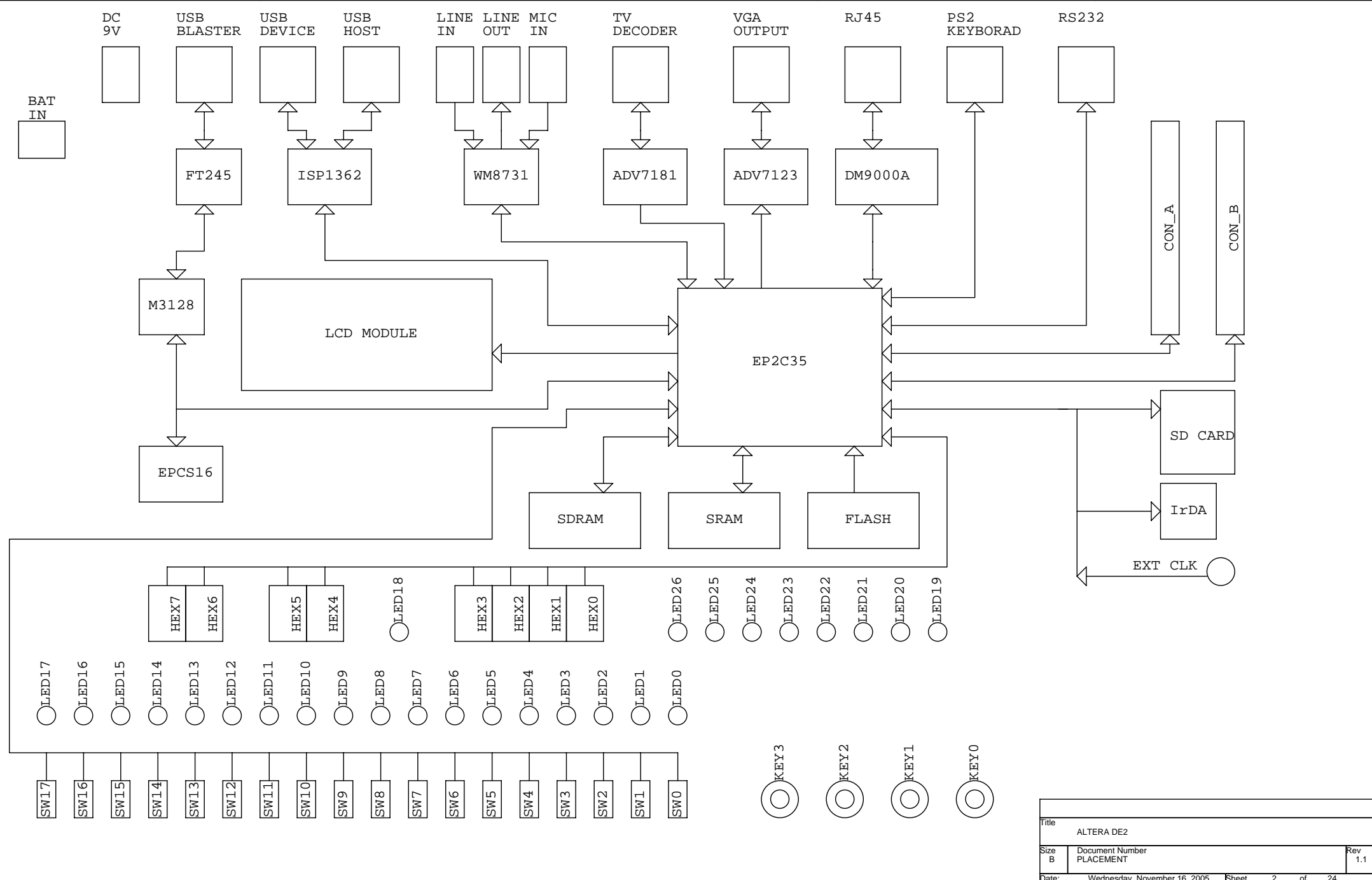

Title		
ALTERA DE2		
Size	Document Number	Rev
B	PLACEMENT	1.1
Date:	Wednesday, November 16, 2005	Sheet 2 of 24

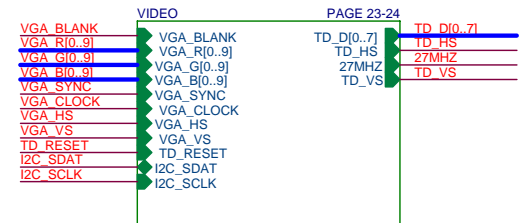
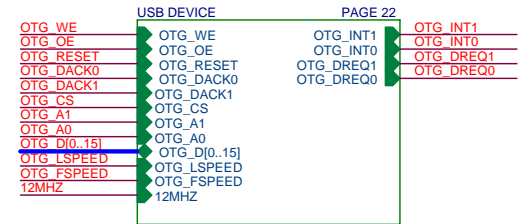
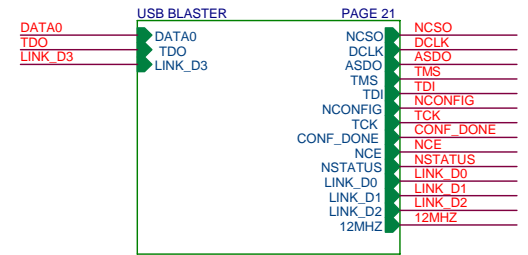
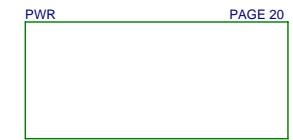
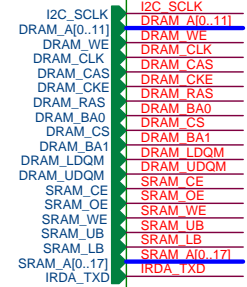
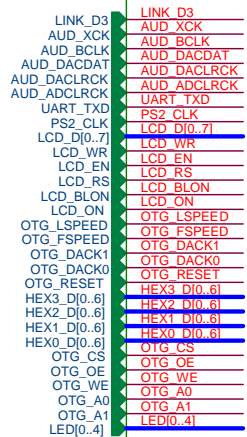
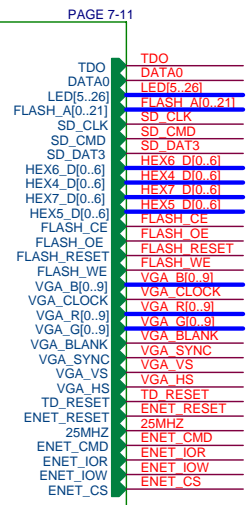
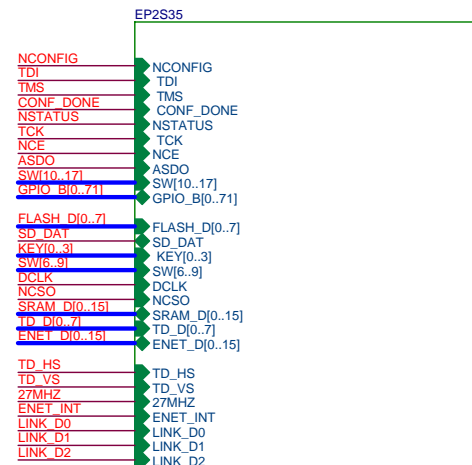
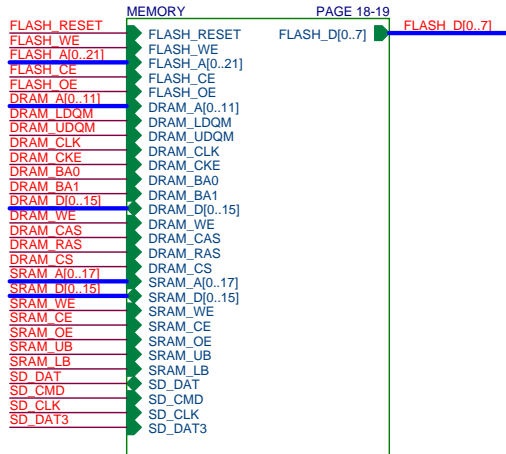
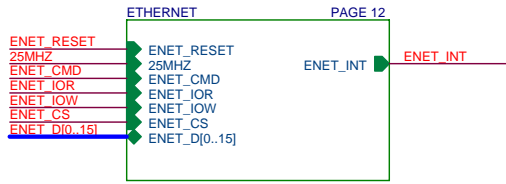
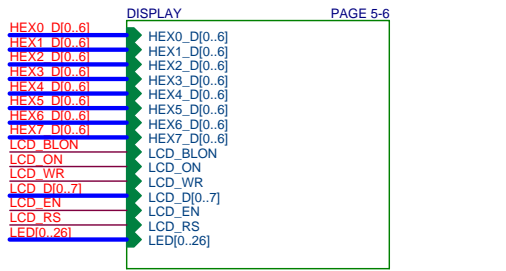
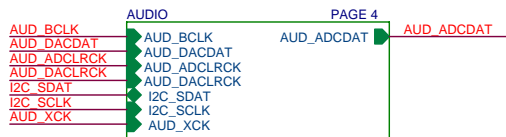

Title		
ALTERA DE2		
Size	Document Number	Rev
B	TOP LEVEL	1.1
Date:	Wednesday, November 16, 2005	Sheet 3 of 24

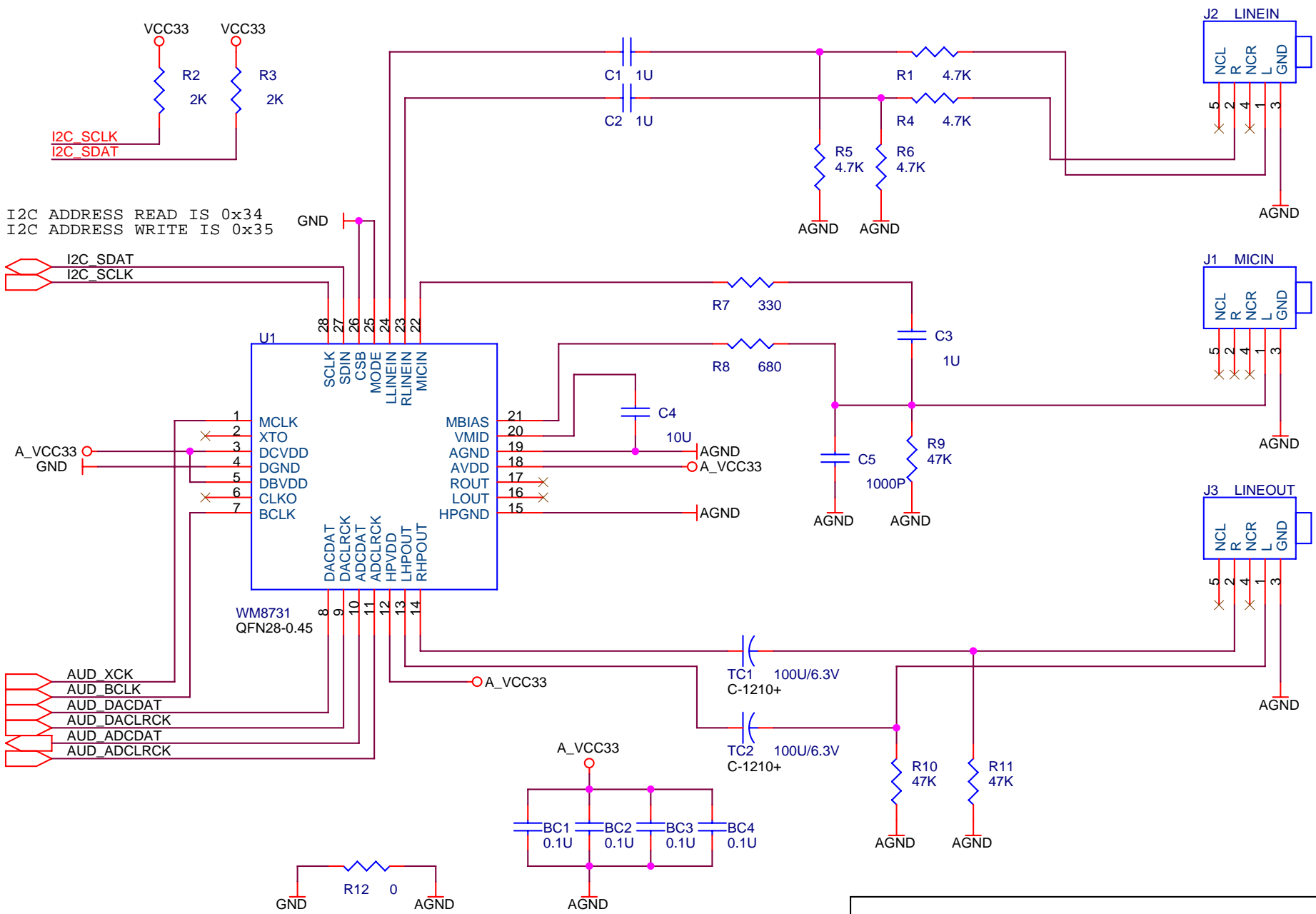

I2C ADDRESS READ IS 0x34
 I2C ADDRESS WRITE IS 0x35

Title		
ALTERA DE2		
Size	Document Number	Rev
A	AUDIO	1.1
Date:	Wednesday, November 16, 2005	Sheet 4 of 24

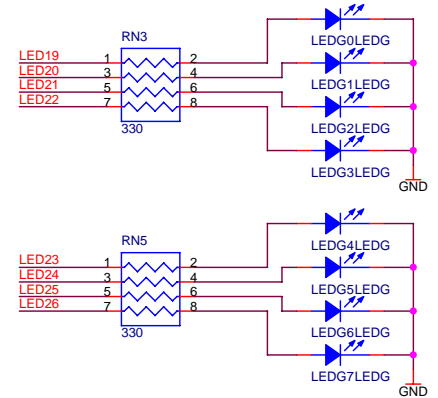
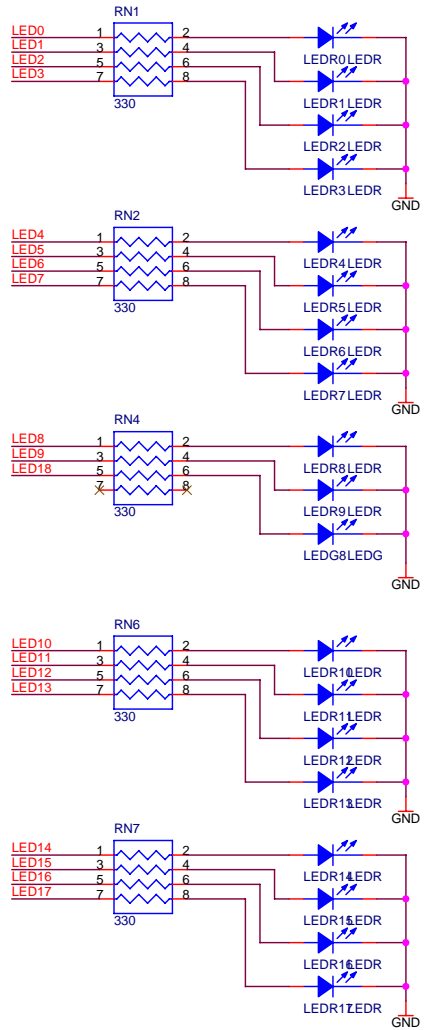
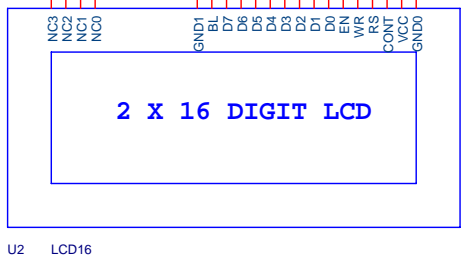
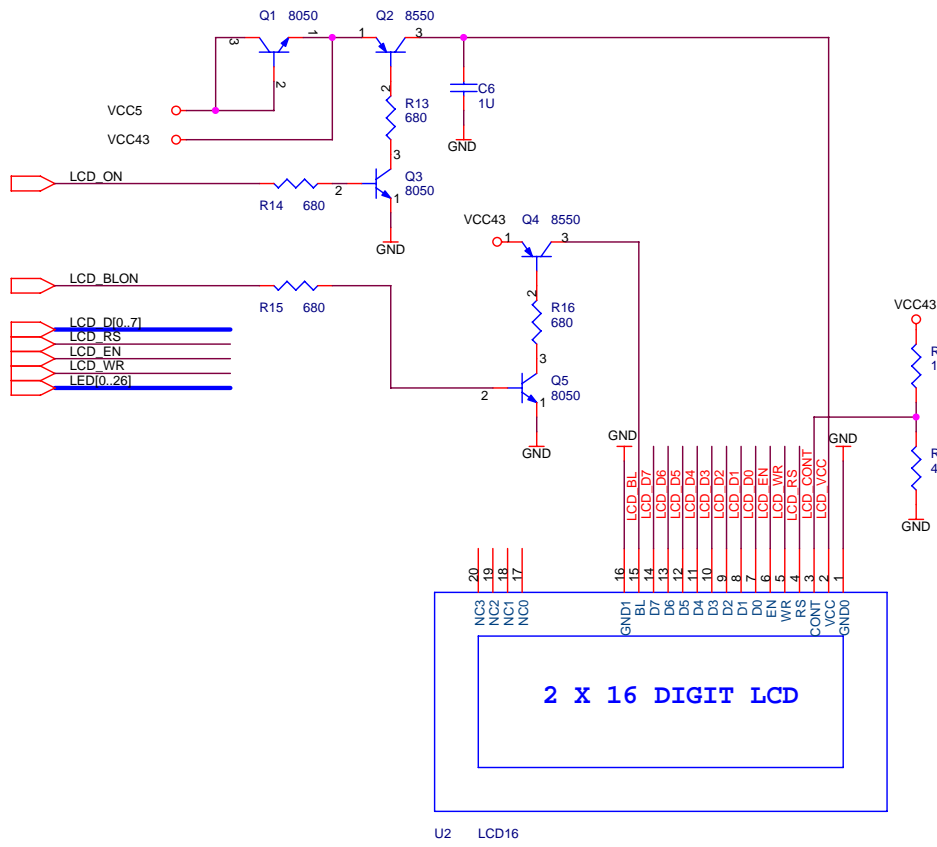

Title		
ALTERA DE2		
Size	Document Number	Rev
B	LCD AND LED	1.1
Date:	Friday, November 18, 2005	Sheet 5 of 24

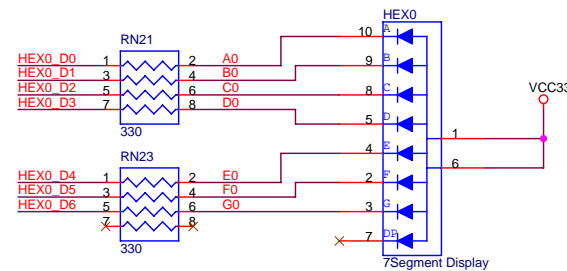
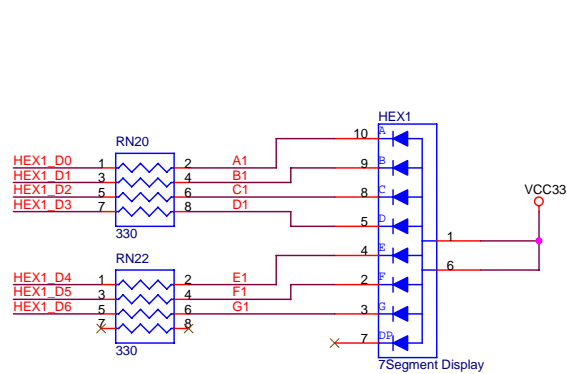
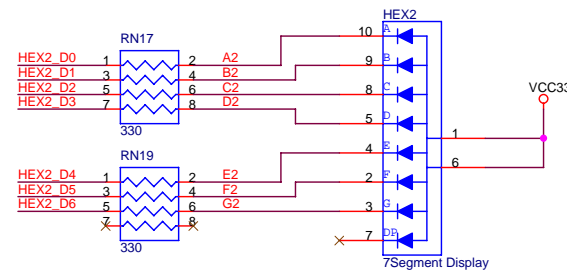
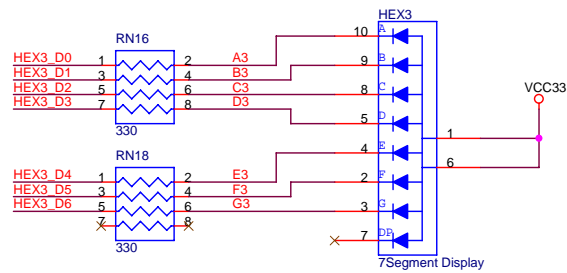
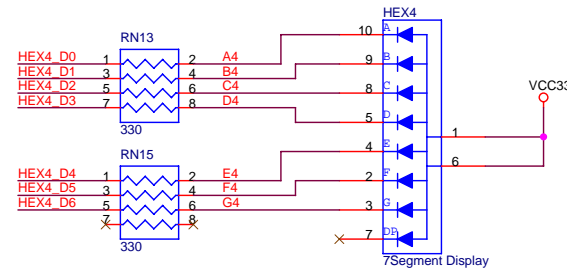
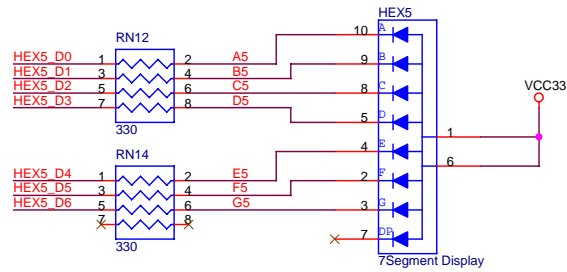
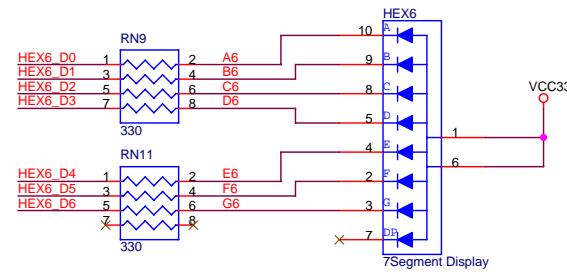
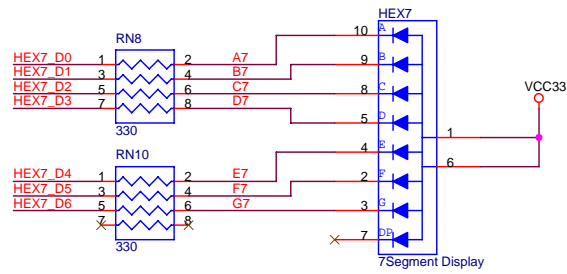
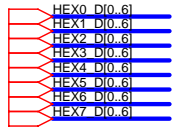

Title		
ALTERA DE2		
Size	Document Number	Rev
B	7 SEGMENT	1.1
Date:	Wednesday, November 16, 2005	Sheet 6 of 24

HEX7 D[0..6]
 HEX6 D[0..6]
 HEX5 D[0..6]
 HEX4 D[0..6]

DRAM D[0..15]
 DRAM A[0..11]
 DRAM UDQM
 DRAM LDQM
 DRAM CLK
 DRAM CKE
 DRAM BA0
 DRAM BA1
 DRAM WE
 DRAM CAS
 DRAM RAS
 DRAM CS

LCD ON
 LCD BLON
 LCD RS
 LCD EN
 LCD WR
 LCD D[0..7]

SW[10..17]

OTG INT1
 OTG INTO
 OTG DREQ1
 OTG DREQ0
 OTG DACK1
 OTG DACK0
 OTG RESET
 OTG A1
 OTG A0
 OTG CS
 OTG WE
 OTG OE
 OTG LSPEED
 OTG FSPEED

OTG D[0..15]
 50MHZ

GND Y6
 VCC12 Y7
 GND WZ
 DRAM_CKE AA6
 DRAM_CLK AA7
 DRAM_CS AC3
 DRAM_RAS AB4
 DRAM_CAS AB3
 DRAM_BA1 AE3
 DRAM_BA0 AE2
 DRAM_WE AD3
 DRAM_LDQM AD2
 DRAM_UDQM Y5
 DRAM_D15 AA5
 DRAM_D14 AC1
 DRAM_D13 AC2
 DRAM_D12 AA3
 DRAM_D11 AA4
 DRAM_D10 AB1
 DRAM_D9 AB2
 DRAM_D8 W6
 DRAM_D7 V7
 DRAM_D6 T8
 DRAM_D5 R8
 DRAM_D4 Y4
 DRAM_D3 Y3
 DRAM_D2 AA1
 DRAM_D1 AA2
 DRAM_D0 V6
 DRAM_A11 V5
 DRAM_A10 Y1
 DRAM_A9 W3
 DRAM_A8 W4
 DRAM_A7 U5
 DRAM_A6 U7
 DRAM_A5 U6
 DRAM_A4 T4
 DRAM_A3 W1
 DRAM_A2 W2
 DRAM_A1 V3
 DRAM_A0 V4
 DRAM_A0 T6
 SW13 T7
 SW17 V2
 SW16 V1
 SW15 U4
 SW14 U3
 HEX4_D0 X U10
 HEX4_D1 U9
 HEX4_D2 U1
 HEX4_D3 U2
 HEX4_D4 T4
 HEX4_D5 R6
 HEX4_D6 T3
 HEX5_D0 T2
 HEX5_D1 P6
 HEX5_D2 P7
 HEX5_D3 T9
 HEX5_D4 X T10
 HEX5_D5 R5
 HEX5_D6 R4
 HEX6_D0 R3
 HEX6_D1 R2
 HEX6_D2 P4
 SW11 P1
 SW12 P2



BANK 1

CYCLONE II EP2C35

SW10 N1
 50MHZ N2
 HEX6 D3 M2
 HEX6 D4 M3
 HEX6 D5 M5
 HEX6 D6 M4
 B1_IO_0 L10
 B1_L0N L3
 B1_L0P L2
 HEX7 D0 L3
 HEX7 D1 L2
 HEX7 D2 L9
 HEX7 D3 L6
 HEX7 D4 L7
 HEX7 D5 P9
 HEX7 D6 P8
 LCD_ON L4
 LCD_BLON K2
 LCD_RS K1
 LCD_EN K3
 LCD_WR K4
 LCD_D0 J1
 LCD_D1 J2
 LCD_D2 H1
 LCD_D3 H2
 LCD_D4 J4
 LCD_D5 J3
 LCD_D6 H4
 LCD_D7 H3
 OTG_OE G2
 OTG_WE G1
 OTG_CS F1
 OTG_A1 F2
 OTG_A0 K7
 OTG_D15 K8
 OTG_D14 J6
 OTG_D13 G3
 OTG_D12 G4
 OTG_D11 G4
 OTG_D10 K5
 OTG_D9 K6
 OTG_D8 E2
 OTG_D7 H6
 OTG_D6 J7
 OTG_D5 J8
 OTG_D4 J5
 OTG_D3 F7
 OTG_D2 D1
 OTG_D1 D2
 OTG_D0 F4
 OTG_FSPPEED F3
 OTG_LSPPEED F3
 OTG_RESET G6
 OTG_INT1 C3
 OTG_DACK0 C2
 OTG_DREQ0 F6
 OTG_DREQ1 E5
 OTG_INT0 B3
 OTG_DACK1 B2
 GND G7
 VCC12 H7
 GND E4

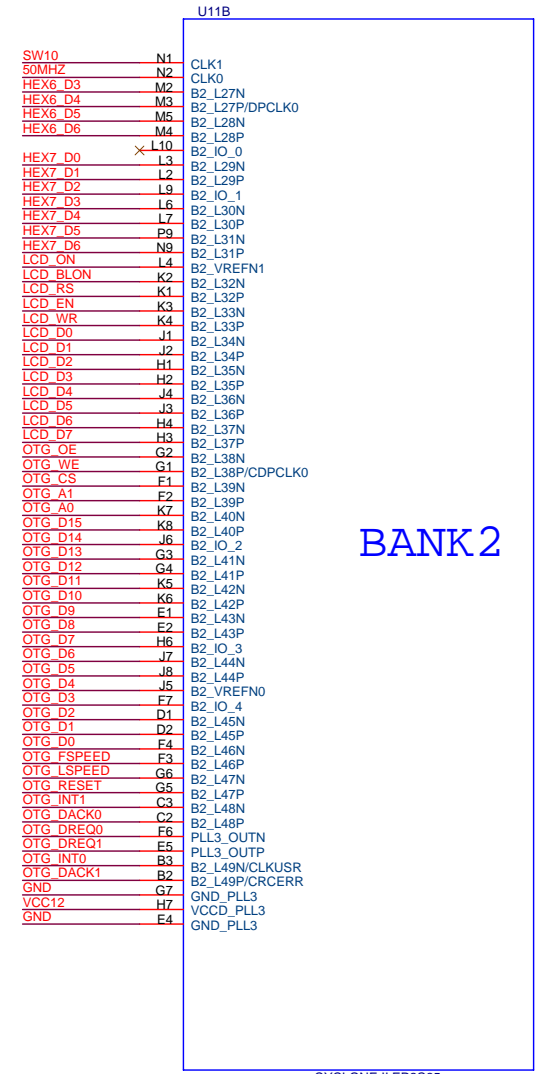

BANK 2

CYCLONE II EP2C35

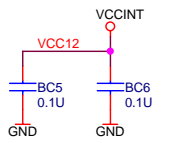

Title		
ALTERA DE2		
Size	Document Number	Rev
B	EP2C35 BANK1 AND BANK 2	1.1
Date:	Wednesday, November 16, 2005	Sheet 7 of 24

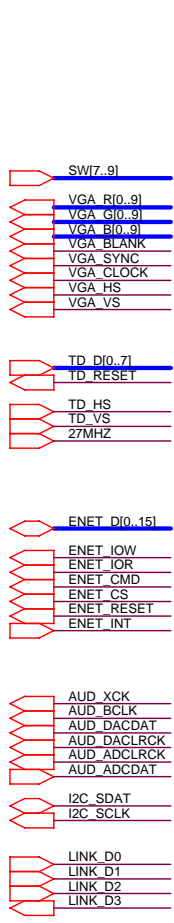

U11C	U11D
VCC12	G8
GND	F8
AUD_ADCLRCK	C5
AUD_DACLRCK	C6
AUD_DACDAT	A4
AUD_BCLK	B4
AUD_XCK	A5
AUD_ADCDAT	B5
I2C_SDAT	B6
I2C_SCLK	A6
TD_RESET	C4
TD_HS	D5
TD_VS	K9
TD_D0	J9
TD_D1	E8
TD_D2	H8
TD_D3	H10
TD_D4	G9
TD_D5	F9
TD_D6	D7
TD_D7	C7
VGA_BLANK	D6
VGA_SYNC	B7
VGA_HS	A7
VGA_VS	D8
VGA_R0	C8
VGA_R1	F10
VGA_R2	G10
VGA_R3	D9
VGA_R4	C9
VGA_CLOCK	B8
VGA_R5	A8
VGA_R6	H11
VGA_R7	H12
VGA_R8	F11
VGA_R9	E10
VGA_G0	B9
VGA_G1	A9
VGA_G2	C10
VGA_G3	D10
VGA_G4	B10
VGA_G5	A10
VGA_G6	G11
VGA_G7	D11
VGA_G8	E12
VGA_G9	D12
VGA_B0	J13
VGA_B1	F14
VGA_B2	F12
VGA_B3	G12
VGA_B4	J10
VGA_B5	J11
VGA_B6	C11
VGA_B7	B11
VGA_B8	C12
VGA_B9	B12
27MHZ	D13
SW7	C13
VCCA_PLL3	
GND_APLL3	
B3_L50N/DEV_CLRN	
B3_L50P	
B3_L51P	
B3_L51N	
B3_L52P	
B3_L52N	
B3_L53P/CDPCLK7	
B3_L53N	
B3_L54P	
B3_L54N	
B3_L55P	
B3_L55N	
B3_VREFN1	
B3_IO_0	
B3_L56P	
B3_L56N	
B3_IO_1	
B3_L57P	
B3_L57N	
B3_IO_2	
B3_L58P	
B3_L58N	
B3_L59P	
B3_L59N	
B3_L60P	
B3_L60N	
B3_L61P	
B3_L61N	
B3_L62P/DPCLK11	
B3_L62N	
B3_L63P	
B3_L63N	
B3_L64P	
B3_L64N	
B3_L65P	
B3_L65N	
B3_L66P	
B3_L66N	
B3_L67P	
B3_L67N	
B3_IO_3	
B3_VREFN0	
B3_L68P	
B3_L68N	
B3_L69P	
B3_L69N	
B3_L70P	
B3_L70N	
B3_L71P	
B3_L71N	
B3_L72P	
B3_L72N	
B3_L73P/DPCLK10	
B3_L73N	
CLK11	
CLK10	

BANK 3

U11D	U11C
CLK9	
CLK8	
B4_L74P/DPCLK9	
B4_L74N	
B4_IO_0	
B4_L75P	
B4_L75N	
B4_L76P	
B4_L76N	
B4_L77P	
B4_L77N	
B4_L78P	
B4_L78N	
B4_L79P	
B4_L79N	
B4_VREFN1	
B4_L80P	
B4_L80N	
B4_L81P	
B4_L81N	
B4_L82P	
B4_L82N	
B4_L83P	
B4_L83N	
B4_L84P	
B4_L84N	
B4_L85P/DPCLK8	
B4_L85N	
B4_L86P	
B4_L86N	
B4_L87P	
B4_L87N	
B4_L88P	
B4_L88N	
B4_L89P	
B4_L89N	
B4_L90P	
B4_L90N	
B4_L91P	
B4_L91N	
B4_L92P	
B4_L92N	
B4_VREFN0	
B4_IO_1	
B4_L93P	
B4_L93N	
B4_L94P	
B4_L94N	
B4_L95P	
B4_L95N	
B4_L96P/CDPCLK6	
B4_L96N	
B4_L97P	
B4_L97N	
B4_L98P	
B4_L98N	
B4_L99P	
B4_L99N	
GND_APLL2	
VCCA_PLL2	

BANK 4

CYCLONE II EP2C35

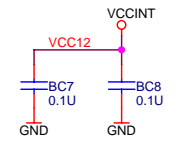

Title		
ALTERA DE2		
Size	Document Number	Rev
B	EP2C35 BANK3 AND BANK 4	1.1
Date:	Wednesday, November 16, 2005	Sheet 8 of 24

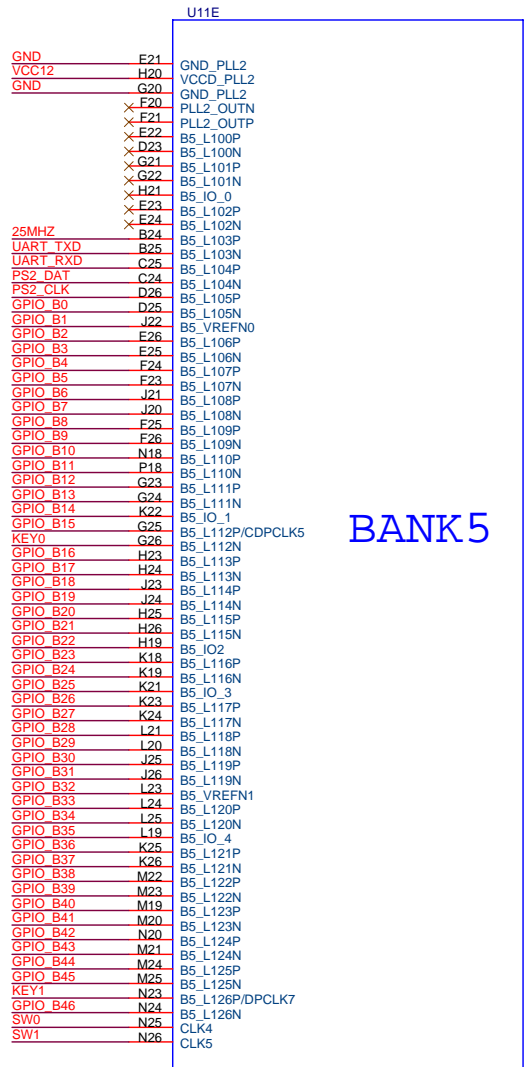

BANK 5

CYCLONE II EP2C35

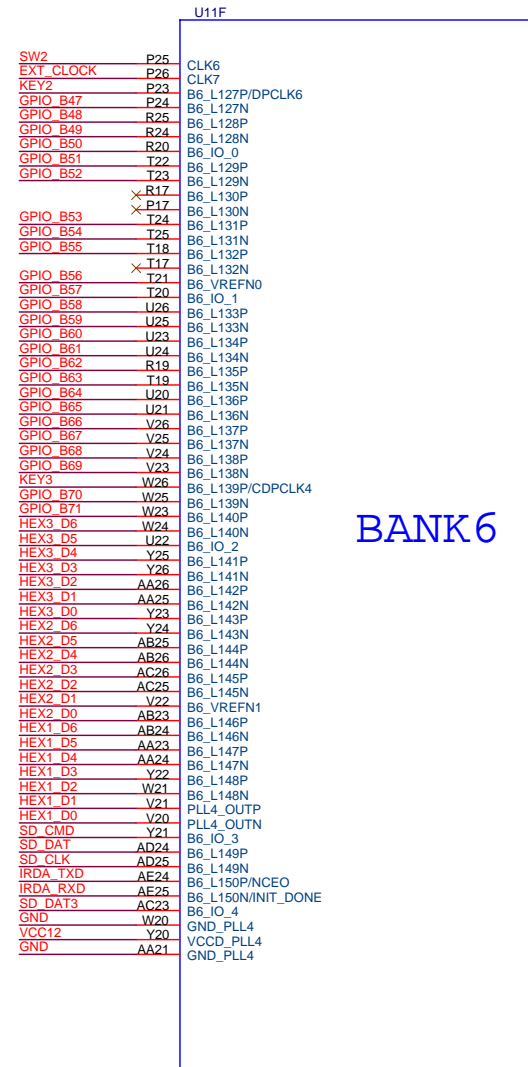

BANK 6

CYCLONE II EP2C35

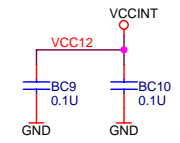

Title		
ALTERA DE2		
Size	Document Number	Rev
B	EP2C35 BANKS AND BANK 6	1.1
Date:	Wednesday, November 16, 2005	Sheet 9 of 24

U11G

VCC12	AA19	VCCA_PLL4
GND	Y19	GND_A_PLL4
LED0	AE23	B7_L151N
LED1	AF23	B7_L151P
LED2	AB21	B7_L152N
LED3	AC22	B7_L152P
LED4	AD22	B7_L153N
LED5	AD23	B7_L153P
LED6	AD21	B7_L154N
LED7	AC21	B7_L154P/CDPCLK3
LED19	AE22	B7_L155N
LED20	AE22	B7_L155P
LED21	W19	B7_L156N
LED22	V18	B7_L156P
LED23	U18	B7_L157N
LED24	U17	B7_L157P
LED25	AA20	B7_IO_0
LED26	Y18	B7_VREFN0
FLASH_D7	AE21	B7_L158N
FLASH_D6	AE21	B7_L158P
FLASH_D5	AC20	B7_L159N
FLASH_D4	AB20	B7_L159P
FLASH_D3	AE20	B7_L160N
FLASH_D2	AE20	B7_L160P
FLASH_D1	AC19	B7_L161N
FLASH_D0	AD19	B7_L161P
FLASH_RESET	AA18	B7_L162N
FLASH_WE	AA17	B7_L162P
FLASH_CE	V17	B7_L163N
FLASH_OE	W17	B7_L163P
FLASH_A0	AC18	B7_L164N
FLASH_A1	AB18	B7_L164P
FLASH_A2	AE19	B7_L165N
FLASH_A3	AF19	B7_L165P/DPCLK5
FLASH_A4	AE18	B7_L166N
FLASH_A5	AF18	B7_L166P
FLASH_A6	Y16	B7_L167N
FLASH_A7	AA16	B7_L167P
FLASH_A8	AD17	B7_L168N
FLASH_A9	AC17	B7_L168P
FLASH_A10	AE17	B7_L169N
FLASH_A11	AF17	B7_L169P
FLASH_A12	W16	B7_L170N
FLASH_A13	W15	B7_L170P
FLASH_A14	AC16	B7_VREFN1
FLASH_A15	AD16	B7_L171N
FLASH_A16	AE16	B7_L171P
FLASH_A17	AC15	B7_L172N
FLASH_A18	AB15	B7_L172P
FLASH_A19	AA15	B7_L173N
FLASH_A20	Y15	B7_L173P
FLASH_A21	Y14	B7_L174N
LED8	AA14	B7_L174P
LED9	Y13	B7_L175N
LED10	AA13	B7_L175P
LED11	AC14	B7_IO_1
LED12	AD15	B7_L176N
LED13	AE15	B7_L176P
SW3	AE14	CLK12
SW4	AF14	CLK13

BANK 7

CYCLONE II EP2C35

U11H

SW5	AD13	CLK14
SW6	AC13	CLK15
LED14	AE13	B8_L177N
LED15	AE13	B8_L177P/DPCLK3
LED16	AE12	B8_L178N
LED17	AD12	B8_L178P
LED18	Y12	B8_L179N
	AA12	B8_L179P
	U12	B8_L180N
	V11	B8_L180P
	V13	B8_L181N
HEX0_D6	V14	B8_L181P
HEX0_D5	V14	B8_L182N
HEX0_D4	AE11	B8_L182P
HEX0_D3	AD11	B8_VREFN0
HEX0_D2	AC12	B8_IO_0
HEX0_D1	AB12	B8_L183N
HEX0_D0	AE10	B8_L183P
SRAM_WE	AE10	B8_L184N
SRAM_CE	AC11	B8_L184P
SRAM_OE	AD10	B8_L185N
SRAM_UB	AF9	B8_L185P
SRAM_LB	AE9	B8_L186N
SRAM_D15	AC10	B8_L186P
SRAM_D14	AC9	B8_L187N
SRAM_D13	W12	B8_L187P
SRAM_D12	W11	B8_L188N
SRAM_D11	AF8	B8_L188P/DPCLK2
SRAM_D10	AE8	B8_L189N
SRAM_D9	AF7	B8_L189P
SRAM_D8	AE7	B8_L190N
SRAM_D7	Y11	B8_L190P
SRAM_D6	AA11	B8_L191N
SRAM_D5	AB10	B8_L191P
SRAM_D4	AA10	B8_L192N
SRAM_D3	AA9	B8_L192P
SRAM_D2	AE6	B8_L193N
SRAM_D1	AE6	B8_L193P
SRAM_D0	AD8	B8_IO_2
SRAM_A17	AC8	B8_L194N
SRAM_A16	AB8	B8_L194P
SRAM_A15	Y10	B8_IO_3
SRAM_A14	W10	B8_VREFN1
SRAM_A13	W8	B8_L195N
SRAM_A12	AC7	B8_L195P
SRAM_A11	V9	B8_L196N
SRAM_A10	V10	B8_L196P
SRAM_A9	AD7	B8_L197N
SRAM_A8	AD6	B8_L197P
SRAM_A7	AE5	B8_L198N
SRAM_A6	AE5	B8_L198P
SRAM_A5	AD5	B8_L199N
SRAM_A4	AD4	B8_L199P
SRAM_A3	AC6	B8_L200P
SRAM_A2	AC5	B8_L200N/DEV_OE
SRAM_A1	AF4	GND_A_PLL1
SRAM_A0	AE4	VCCA_PLL1
GND	Y8	
VCC12	AA8	

BANK 8

CYCLONE II EP2C35

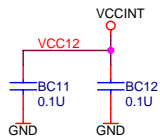
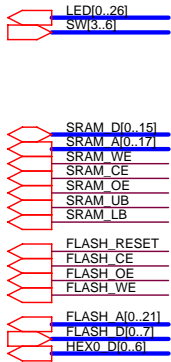

Title		
ALTERA DE2		
Size	Document Number	Rev
B	EP2C35 BANK7 AND BANK 8	1.1
Date:	Wednesday, November 16, 2005	Sheet 10 of 24

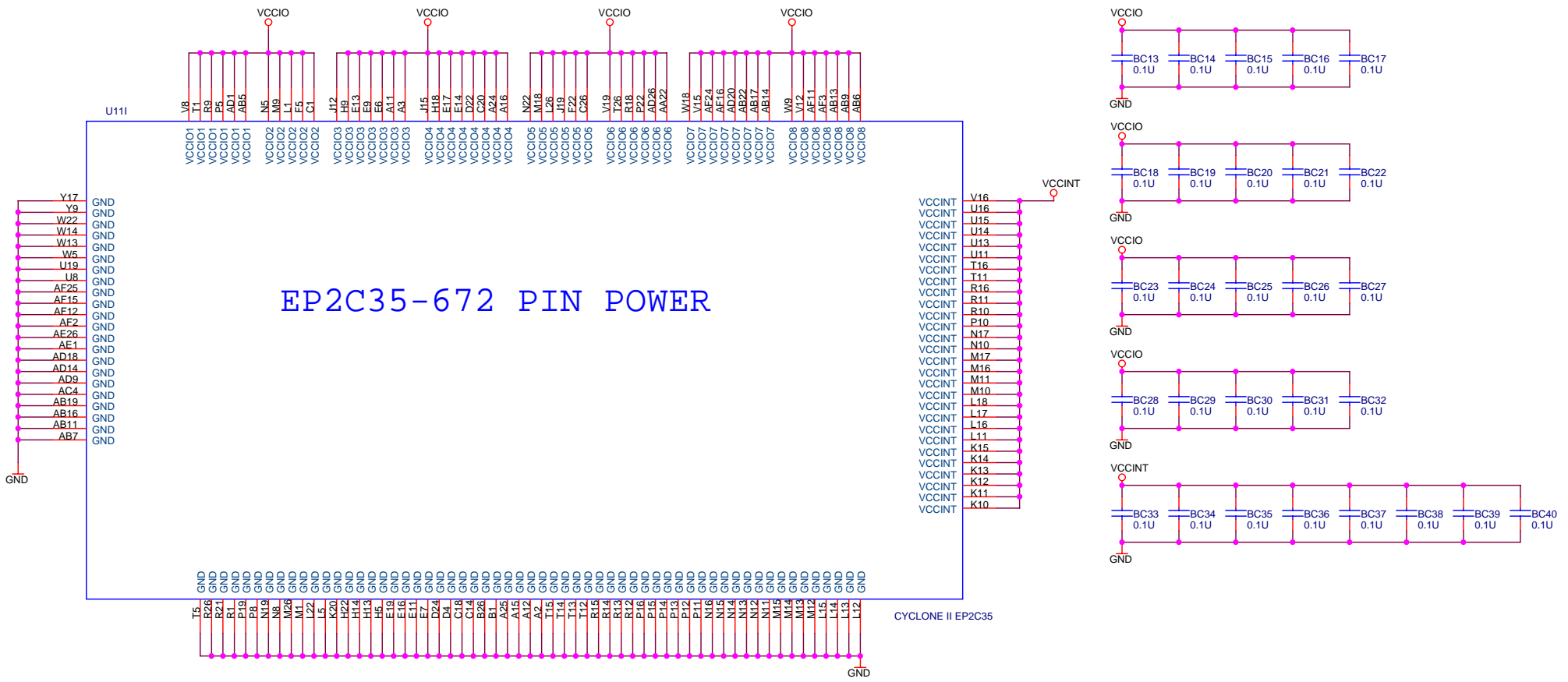

EP2C35-672 PIN POWER

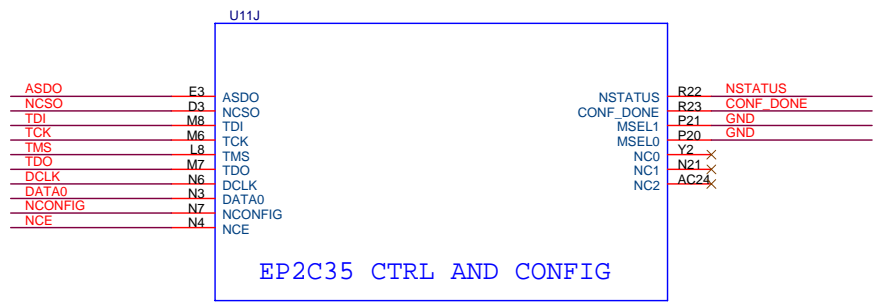
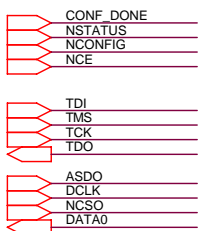

Title		
ALTERA DE2		
Size	Document Number	Rev
B	EP2C35 POWER AND CONFIG	1.1
Date:	Wednesday, November 16, 2005	Sheet 11 of 24

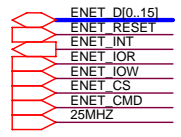
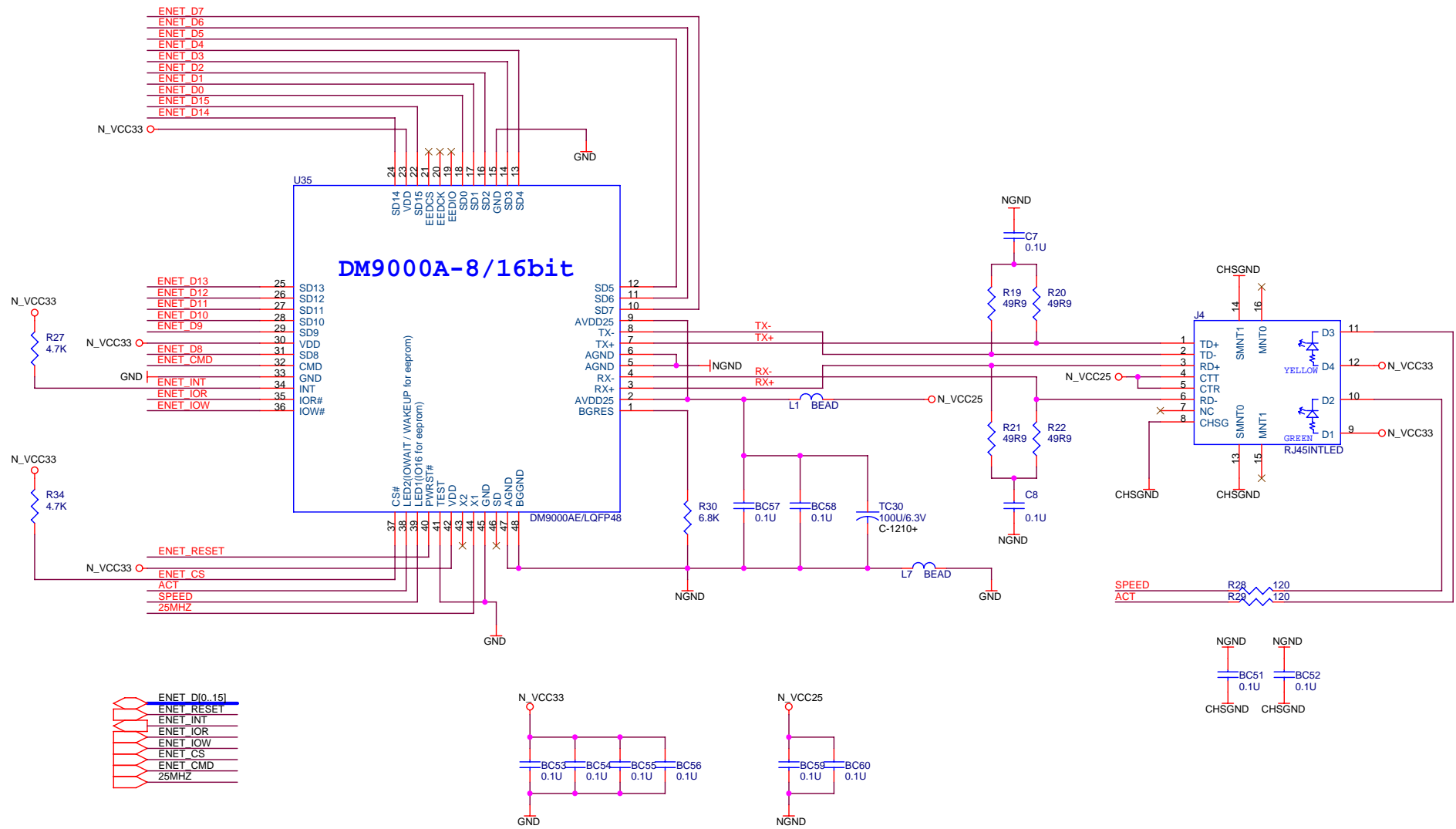

Title		
ALTERA DE2		
Size	Document Number	Rev
B	DM9000AE	1.1
Date:	Wednesday, November 16, 2005	Sheet 12 of 24

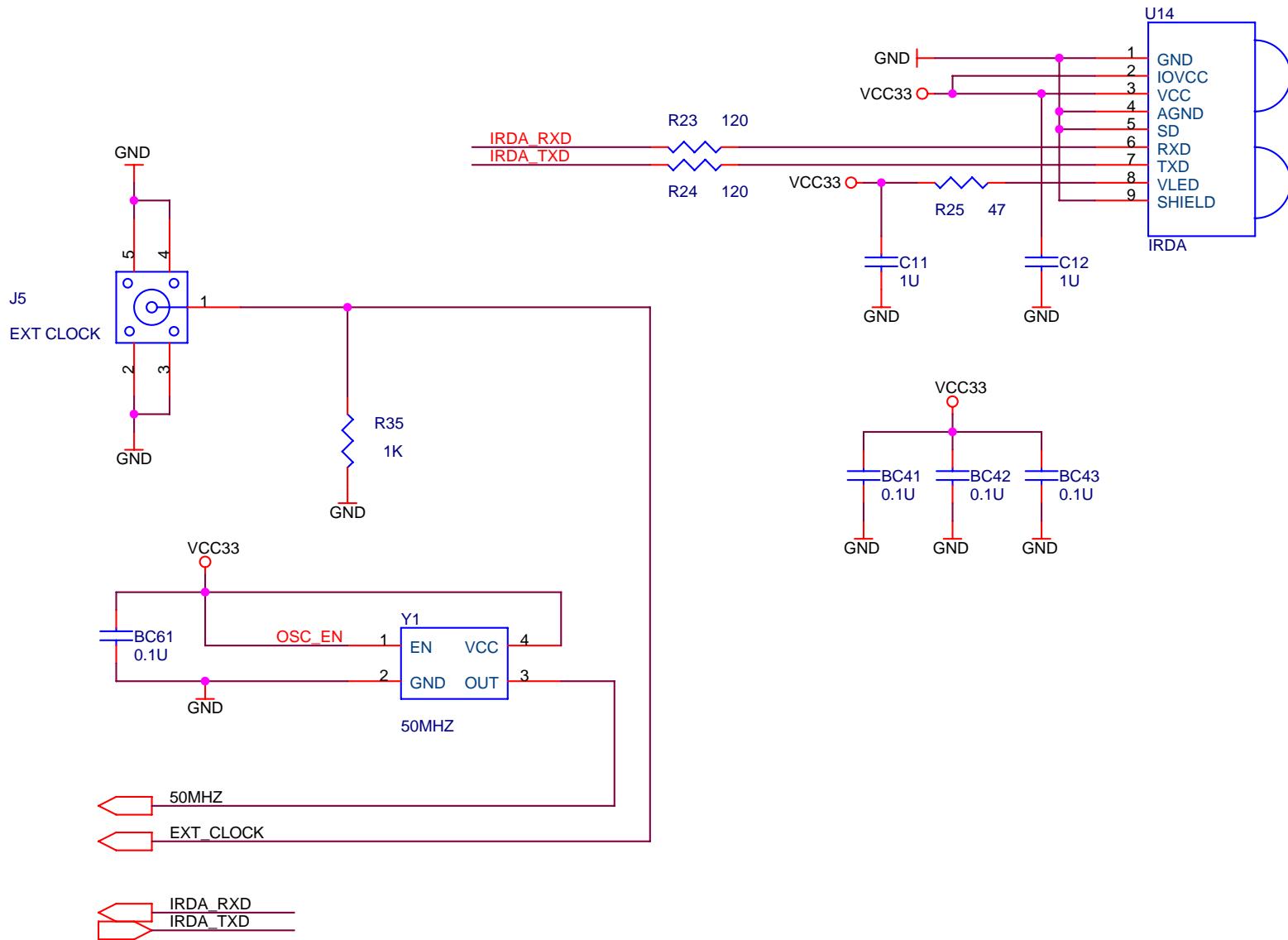

Title		
ALTERA DE2		
Size	Document Number	Rev
A	CLOCK	1.1
Date:	Wednesday, November 16, 2005	Sheet 13 of 24

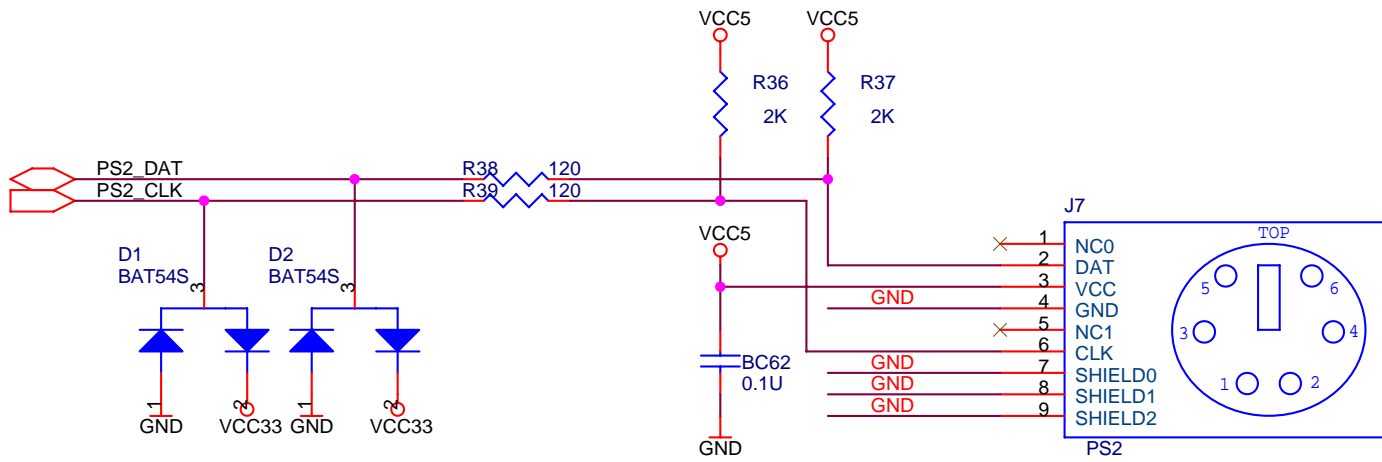
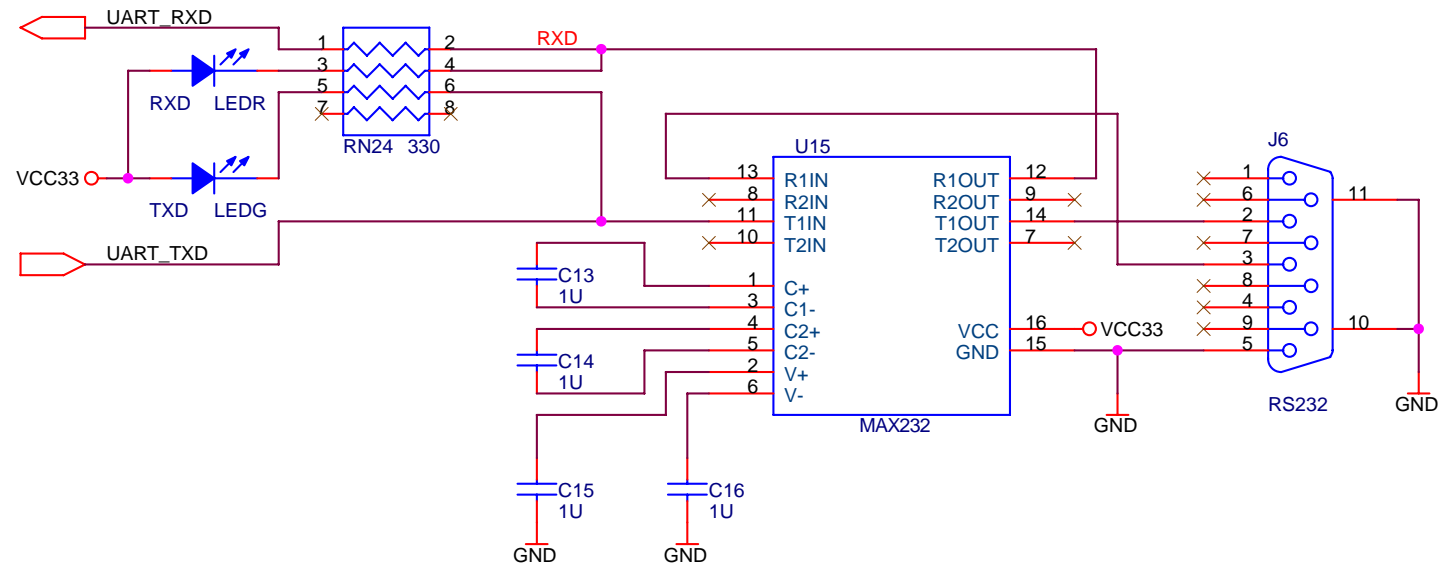

Title		
ALTERA DE2		
Size	Document Number	Rev
A	PS2 AND RS232	1.1
Date:	Wednesday, November 16, 2005	Sheet 14 of 24

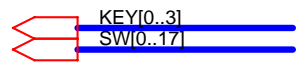
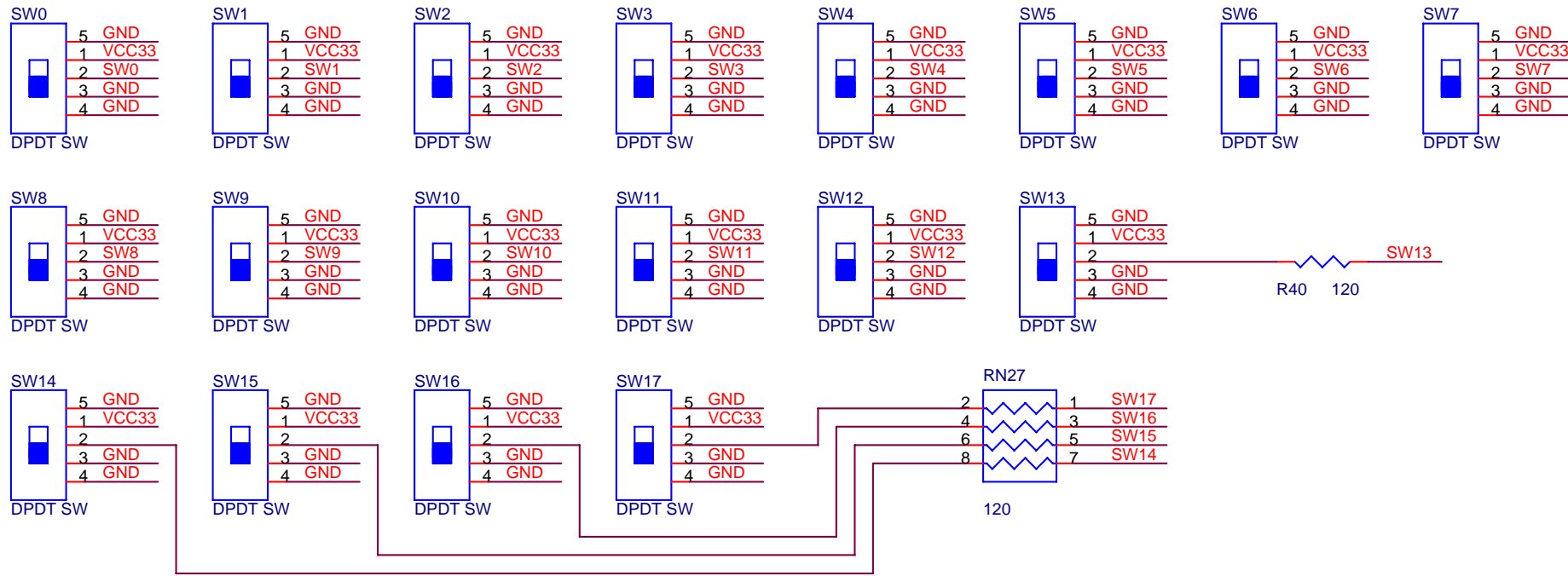
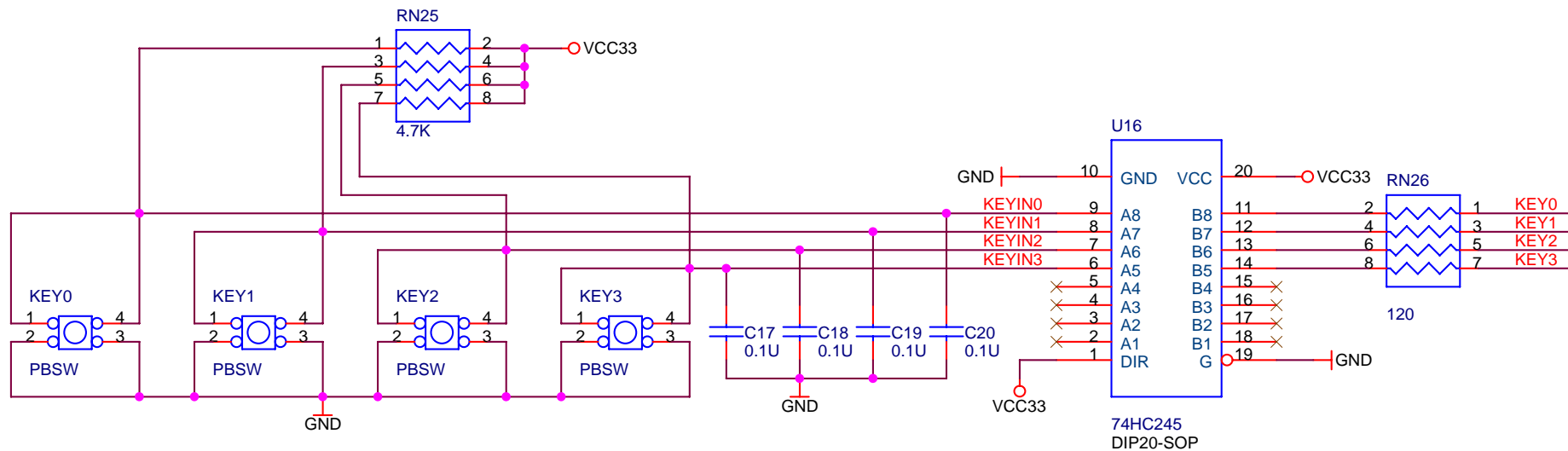

Title		
ALTERA DE2		
Size	Document Number	Rev
A	KEY AND SWITCH	1.1
Date:	Wednesday, November 16, 2005	Sheet 15 of 24

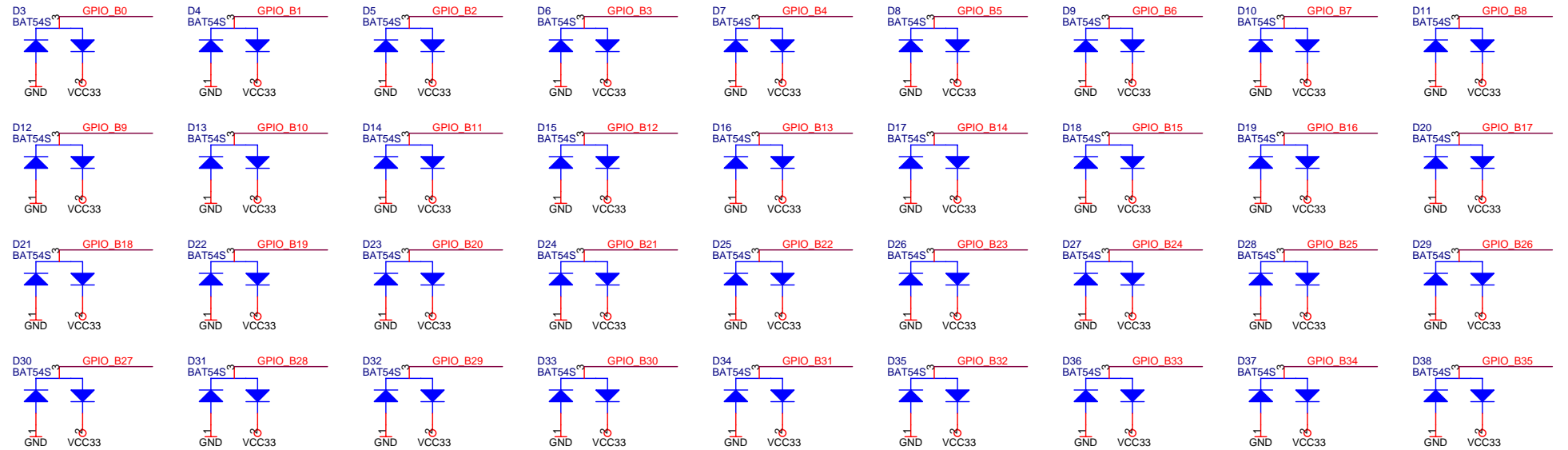

GPIO_B[0..35]

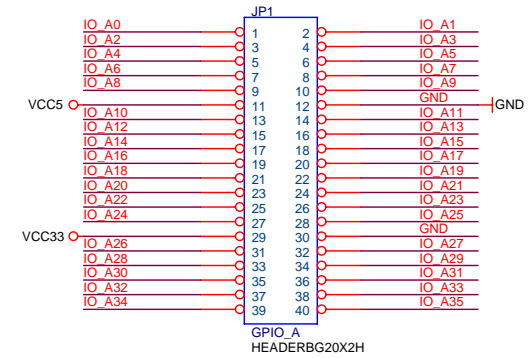
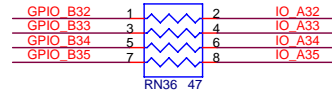
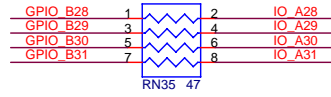
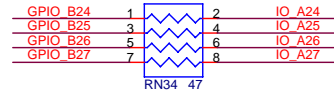
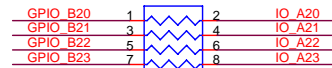
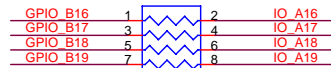
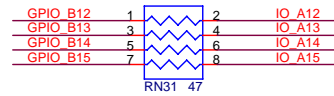
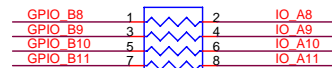
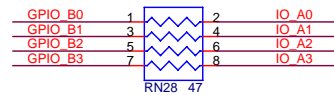

Title		
ALTERA DE2		
Size	Document Number	Rev
B	CONNECT A	1.1
Date:	Wednesday, November 16, 2005	Sheet 16 of 24

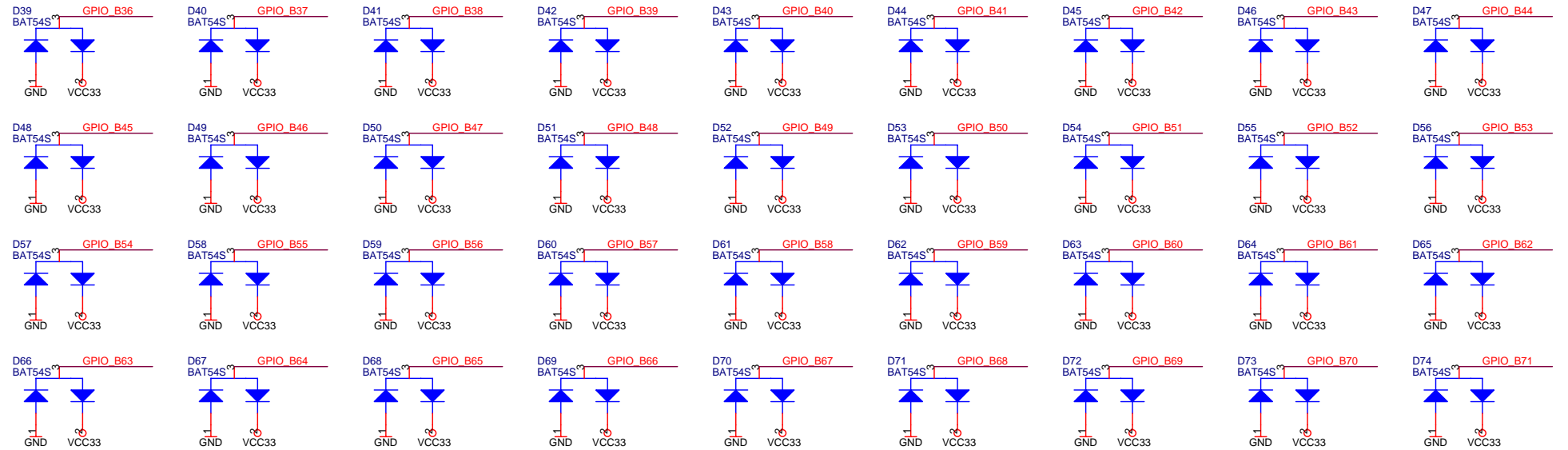

GPIO_B[36..71]

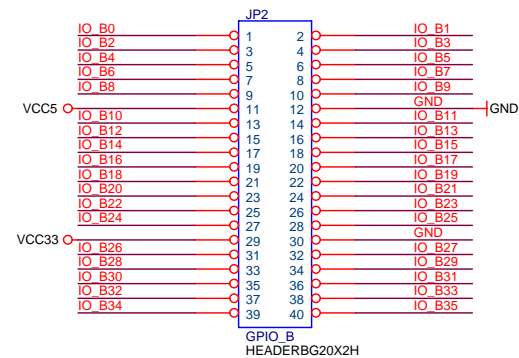
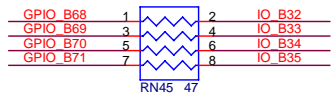
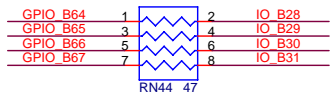
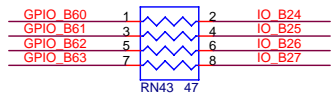
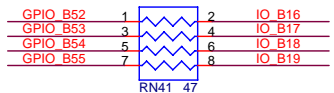
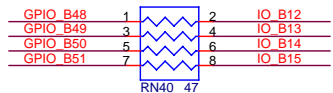
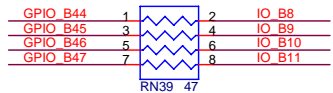
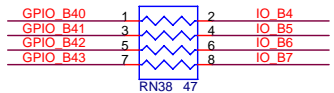
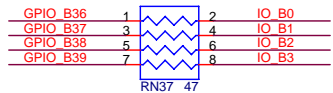

Title		
ALTERA DE2		
Size	Document Number	Rev
B	CONNECT B	1.1
Date:	Wednesday, November 16, 2005	Sheet 17 of 24

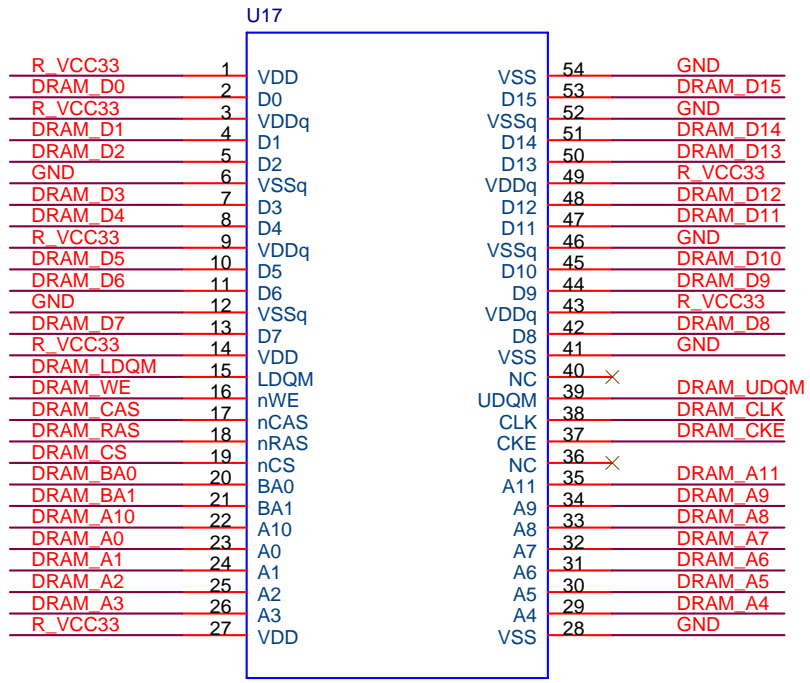

SDRAM 1Mx16x4
DIP54-TSOP

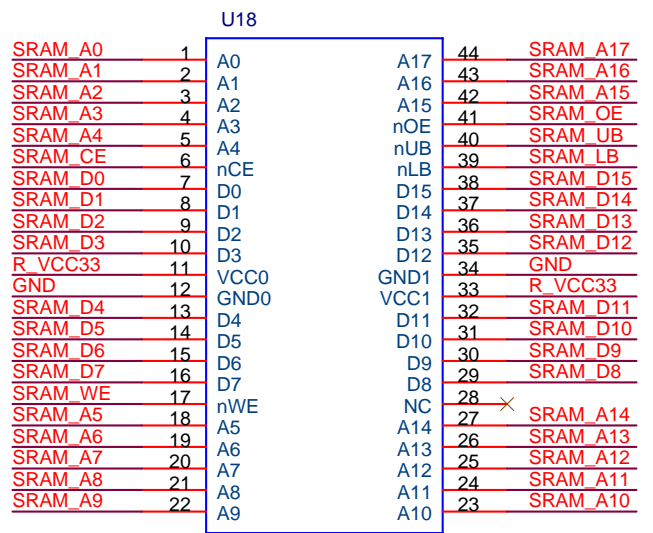

IS61LV25616
DIP44-TSOP

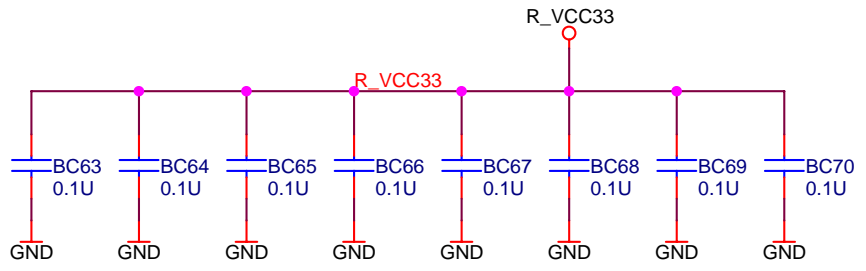
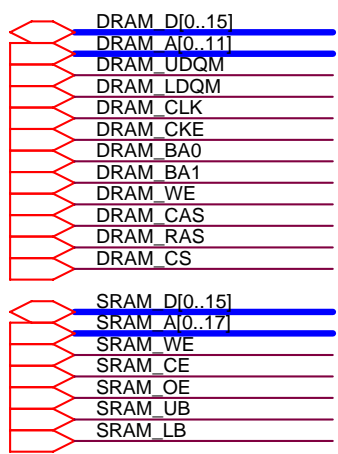
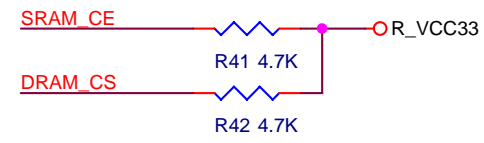

Title		
ALTERA DE2		
Size	Document Number	Rev
A	SDRAM AND SRAM	1.1
Date:	Wednesday, November 16, 2005	Sheet 18 of 24

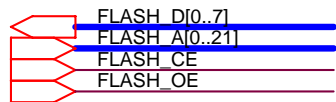
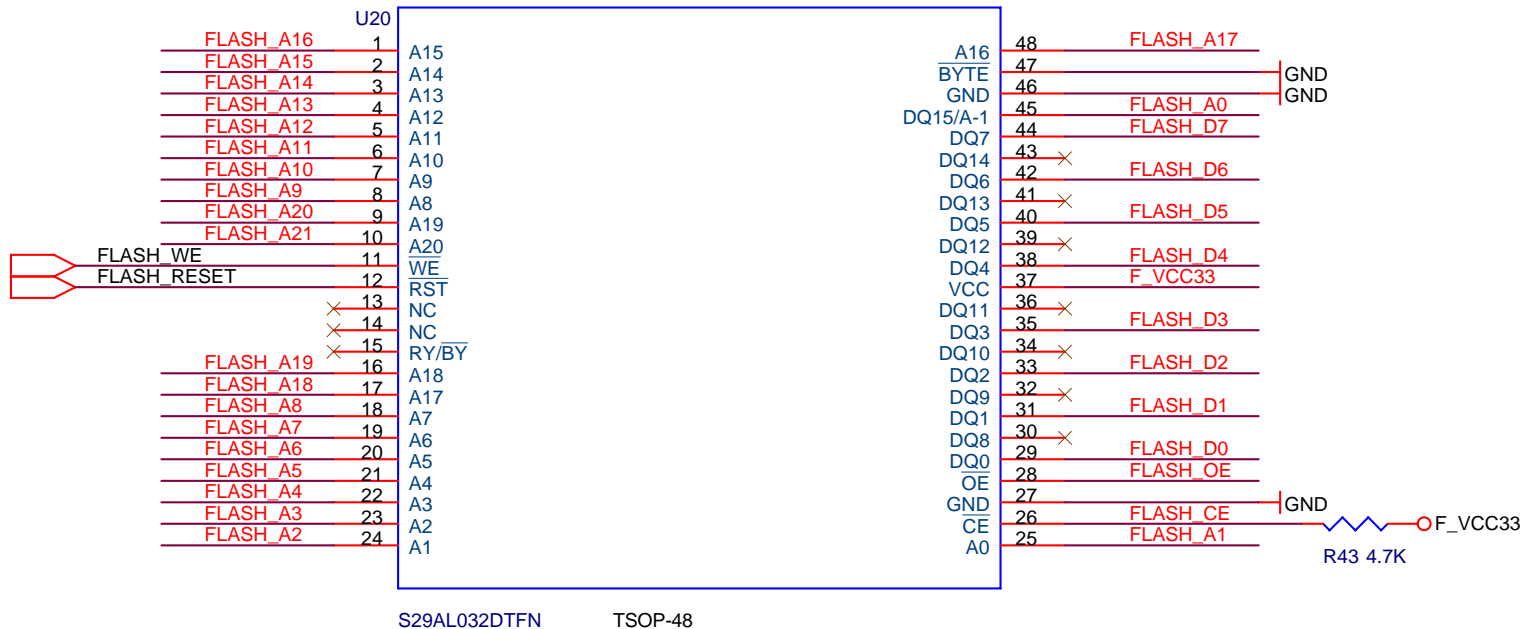
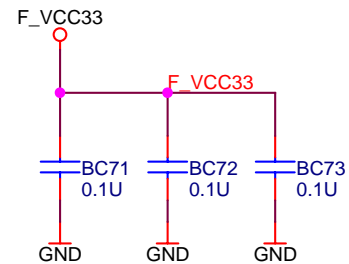
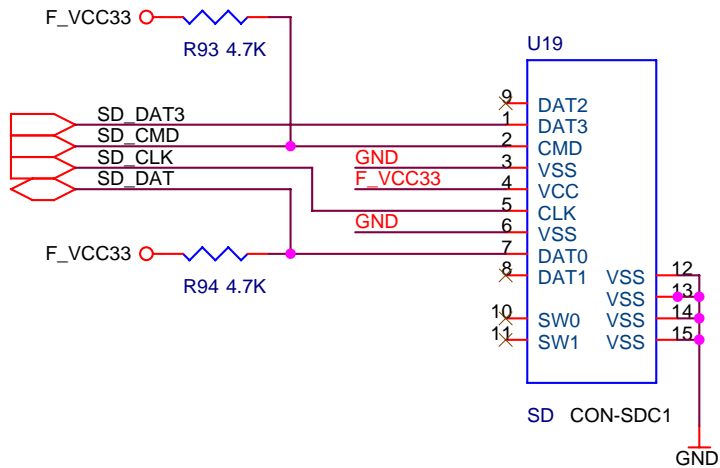

Title		
ALTERA DE2		
Size	Document Number	Rev
A	FLASH	1.1
Date:	Wednesday, November 16, 2005	Sheet 19 of 24

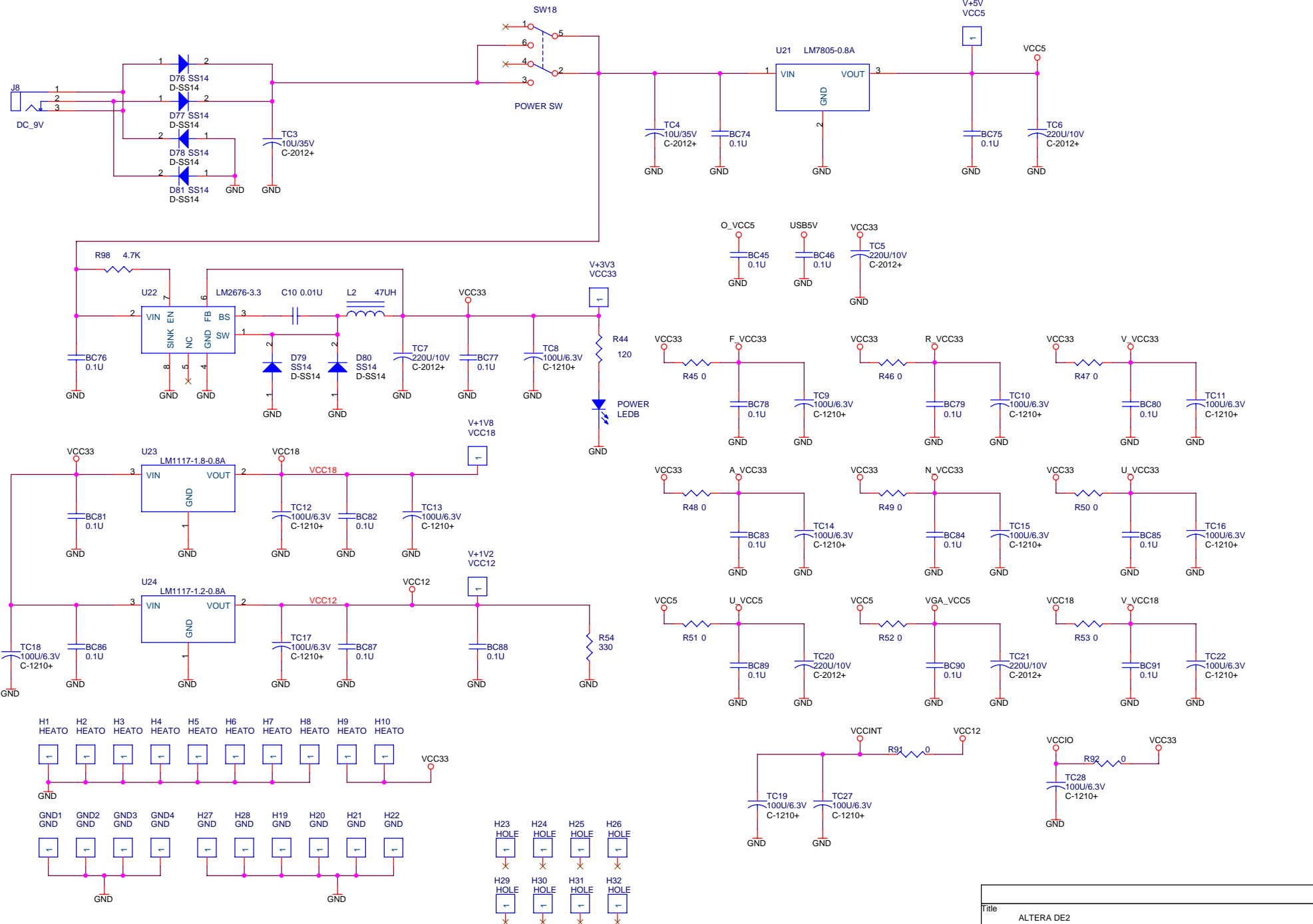

Title		
ALTERA DE2		
Size	Document Number	Rev
CustomPOWER		1.1
Date:	Wednesday, November 16, 2005	Sheet 20 of 24

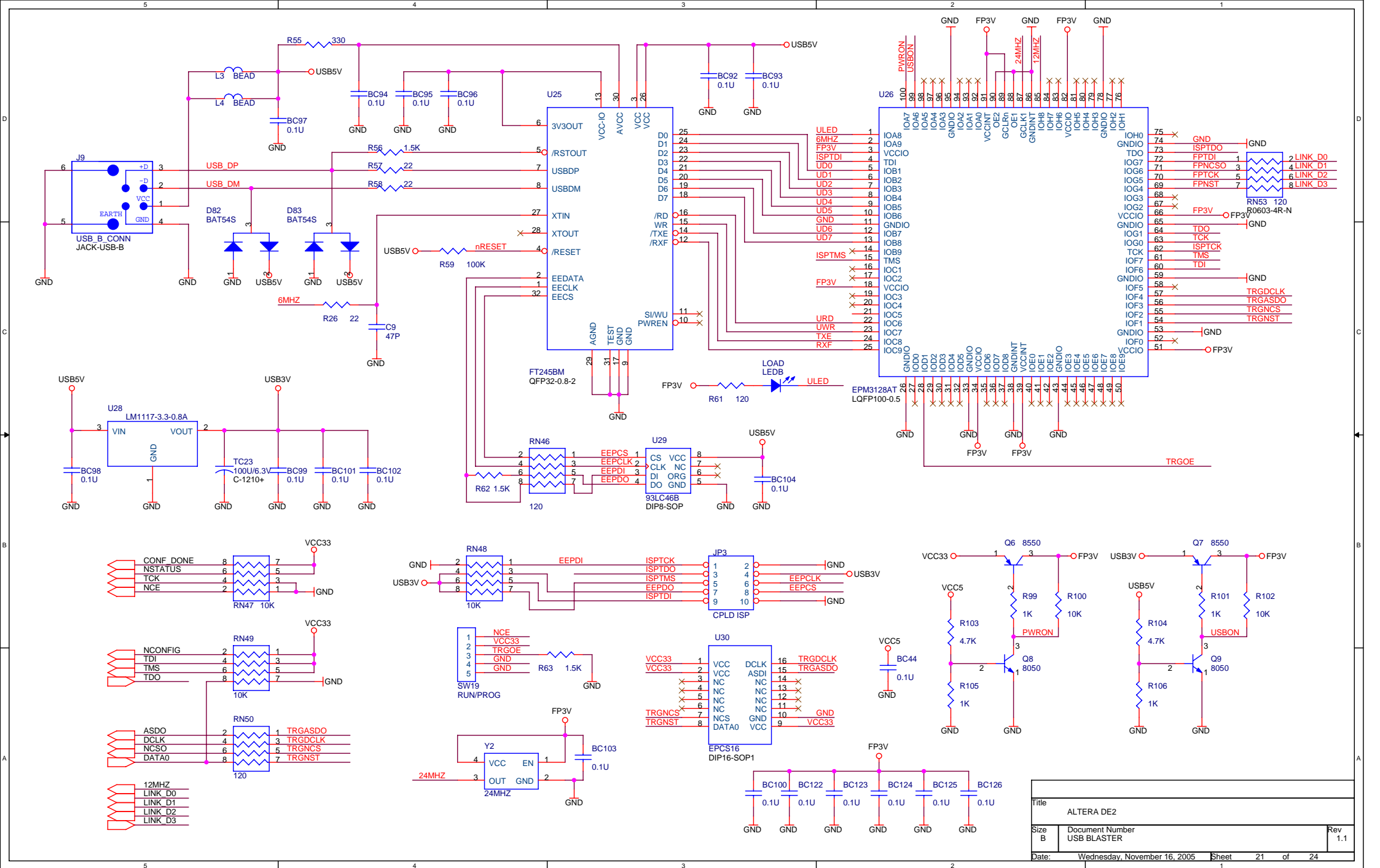

Title		
ALTERA DE2		
Size	Document Number	Rev
B	USB BLASTER	1.1
Date:	Wednesday, November 16, 2005	Sheet 21 of 24

OTG_LSPEED
 OTG_FSPEED
 OTG_D[0..15]

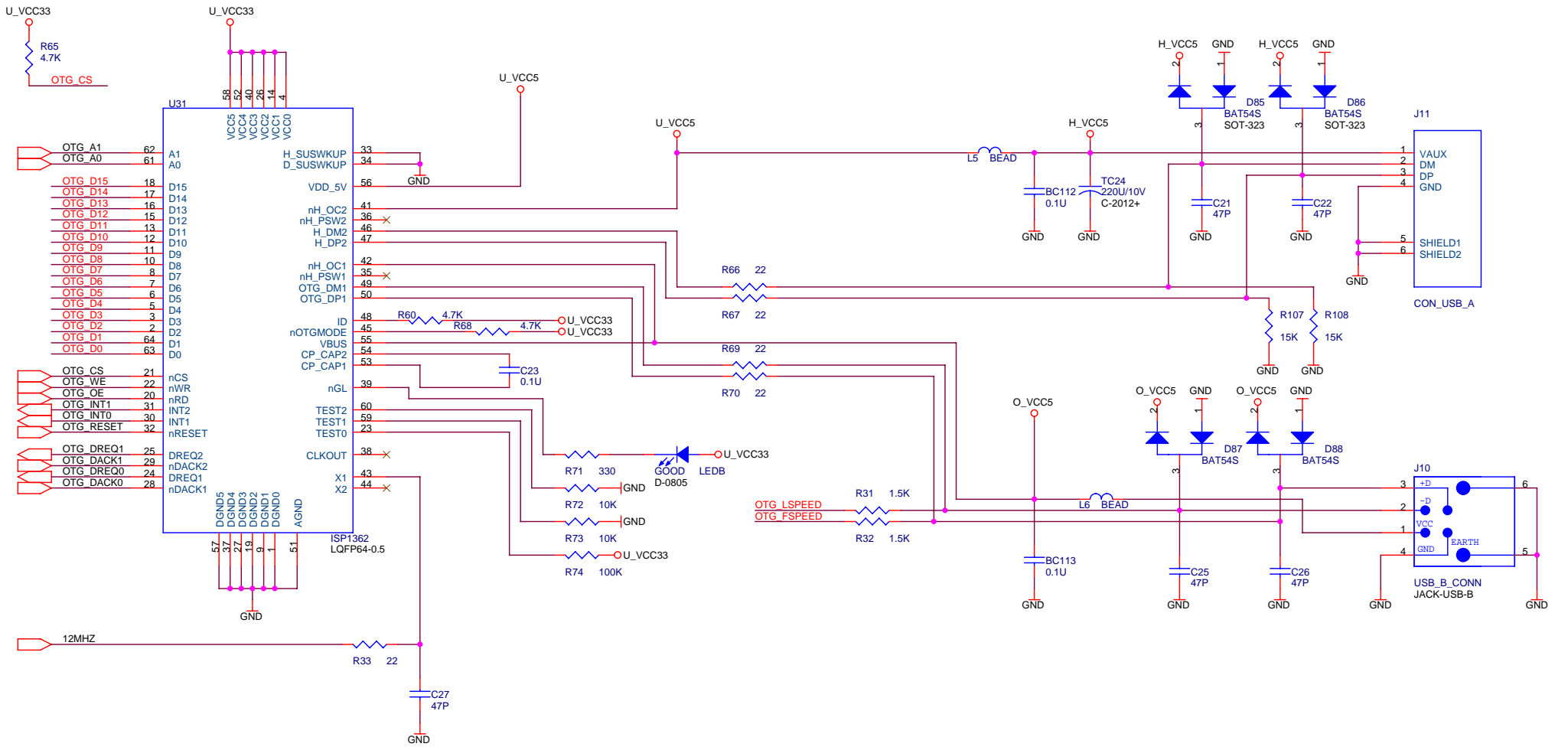

Title		
ALTERA DE2		
Size	Document Number	Rev
B	ISP 1362	1.1
Date:	Wednesday, November 16, 2005	Sheet 22 of 24

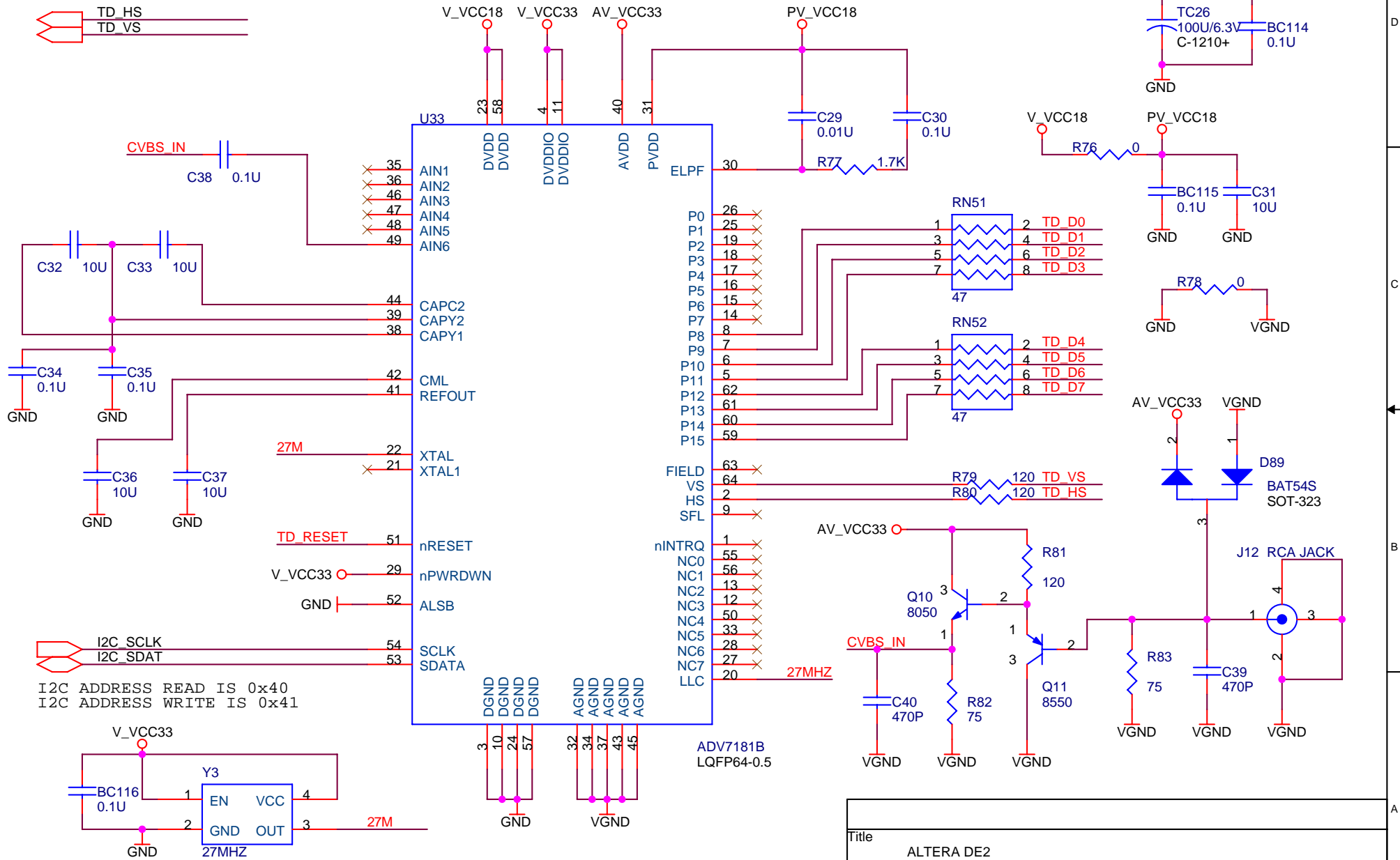
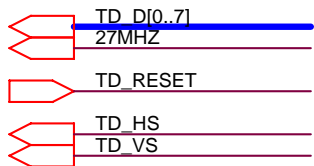

Title		
ALTERA DE2		
Size	Document Number	Rev
A	ADV7181B	1.1
Date:	Wednesday, November 16, 2005	Sheet 23 of 24

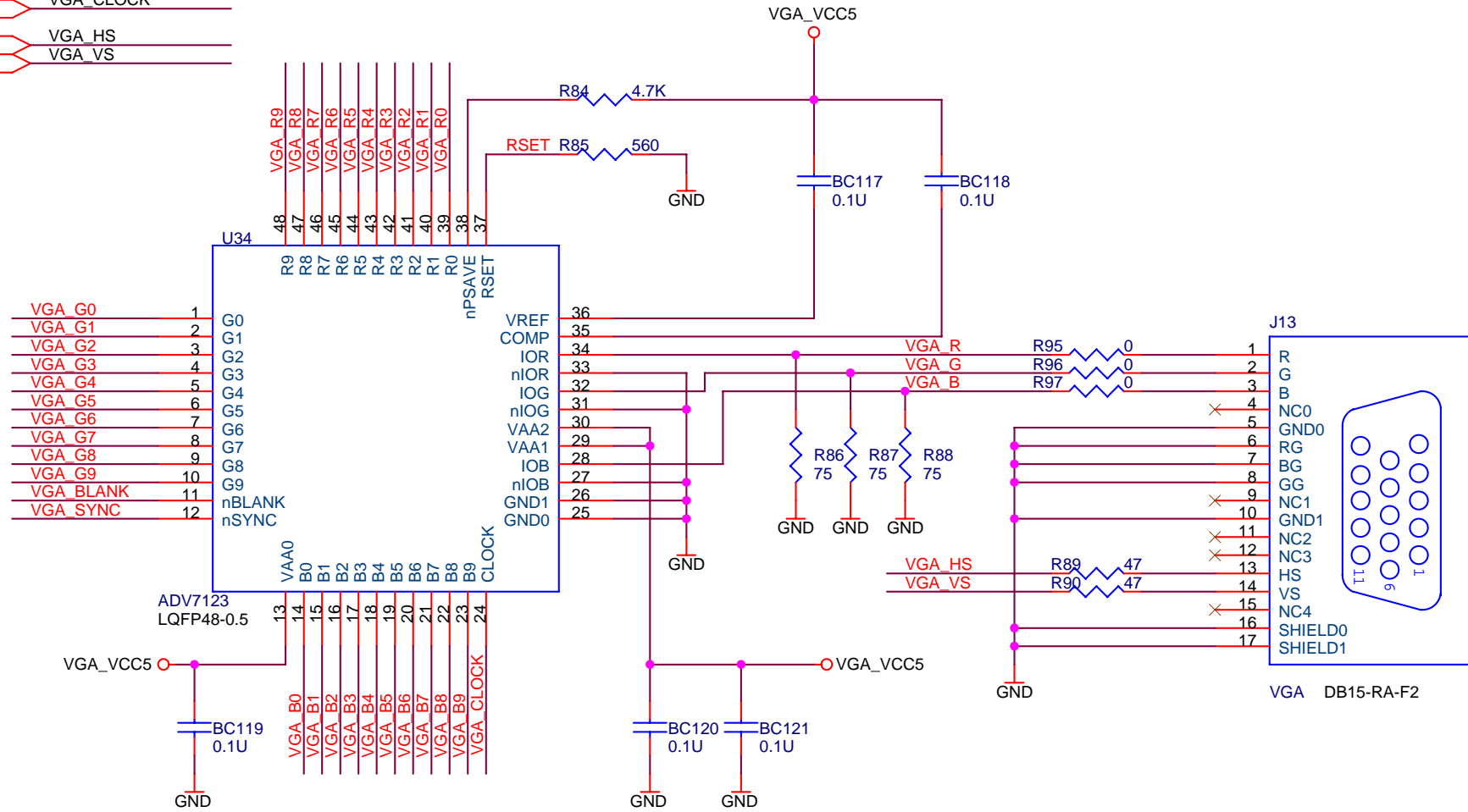
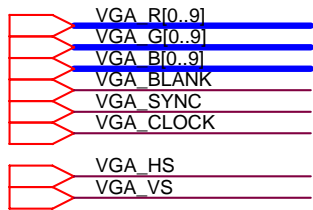

Title		
ALTERA DE2		
Size	Document Number	Rev
A	ADV7123	1.1
Date:	Wednesday, November 16, 2005	Sheet 24 of 24